



# Super Fast DC Charger Instruction Manual

60kw-320kw Fast DC



Shenzhen Secon Power Co., Ltd

# CONTENT

|                                                             |    |
|-------------------------------------------------------------|----|
| Introductions .....                                         | 1  |
| Features.....                                               | 1  |
| Applications .....                                          | 1  |
| Basic User Interface .....                                  | 2  |
| 1. Specification .....                                      | 3  |
| 1.1 Product Specification .....                             | 3  |
| 1.2 Dimmensions (Unit: mm) .....                            | 4  |
| 2. Installation Instruction .....                           | 6  |
| 2.1 Before Installation .....                               | 6  |
| 2.2 Grounding and Safety Requirement .....                  | 7  |
| 2.3 Service Wiring .....                                    | 8  |
| 2.4 Unpack the charger .....                                | 9  |
| 2.5 Recommended Tools for Installation and Inspection ..... | 11 |
| 2.6 Installation Procedure .....                            | 12 |
| 2.7 Installation Inspection & Commissioning .....           | 16 |
| 3. Network Setting .....                                    | 19 |
| 3.1 4G Network Setting .....                                | 19 |
| 3.2 Wi-Fi Network Setting .....                             | 21 |
| 3.3 Ethernet DHCP Network Setting .....                     | 23 |
| 4. Operation Process .....                                  | 25 |
| 4.1 RGB LED indicators .....                                | 25 |
| 4.2 LCD indicators .....                                    | 25 |
| 4.3 Troubleshooting .....                                   | 29 |
| 4.4 Status Codes .....                                      | 30 |
| 5. Maintenance .....                                        | 31 |
| 5.1 General Maintenance .....                               | 31 |
| Limited Product Warranty .....                              | 32 |
| Appendix - Package list .....                               | 33 |

# Introductions

The SeconPower 60kw-320kw Fast DC Charger is the ideal solution for charging battery electric vehicles (BEVs) and plug-in hybrid electric vehicles (PHEVs). Designed for high-power, efficient charging, it is perfect for public and private locations such as commercial parking lots, highway service areas, fleet charging depots, workplace facilities, and residential communities.

Featuring a standalone, robust design, this large-scale DC fast charger supports a wide range of charging applications with a focus on durability and performance. Its modular architecture ensures scalability and easy maintenance, making it a cost-effective choice for long-term use.

Equipped with advanced network communication capabilities, the charger integrates seamlessly with remote management systems, offering real-time updates to users. Drivers can easily locate nearby charging stations, monitor charging progress, and access billing details through a user-friendly interface.

With certifications for safety, waterproof, and dustproof performance, this DC fast charger is built to withstand outdoor environments. Its clear display and intuitive controls make it the reliable choice for businesses and operators seeking to provide top-tier charging services.

## Features

- Offers customers the convenience of start/stop charging control from an authorized RFID smart card or mobile APP.
- Built on latest industry standards for DC charging.
- Carries an outdoor rating capable of withstanding solid and liquid intrusions in outdoor settings making the unit more stable and highly reliable.
- Provides a high-contrast, screen interface with multi-function buttons.

## Applications

- Public and private parking areas
- Community parking areas, Workplace parking areas
- Parking areas of hotels, supermarkets and shopping malls
- Charging stations
- Highway rest are

# Basic User Interface

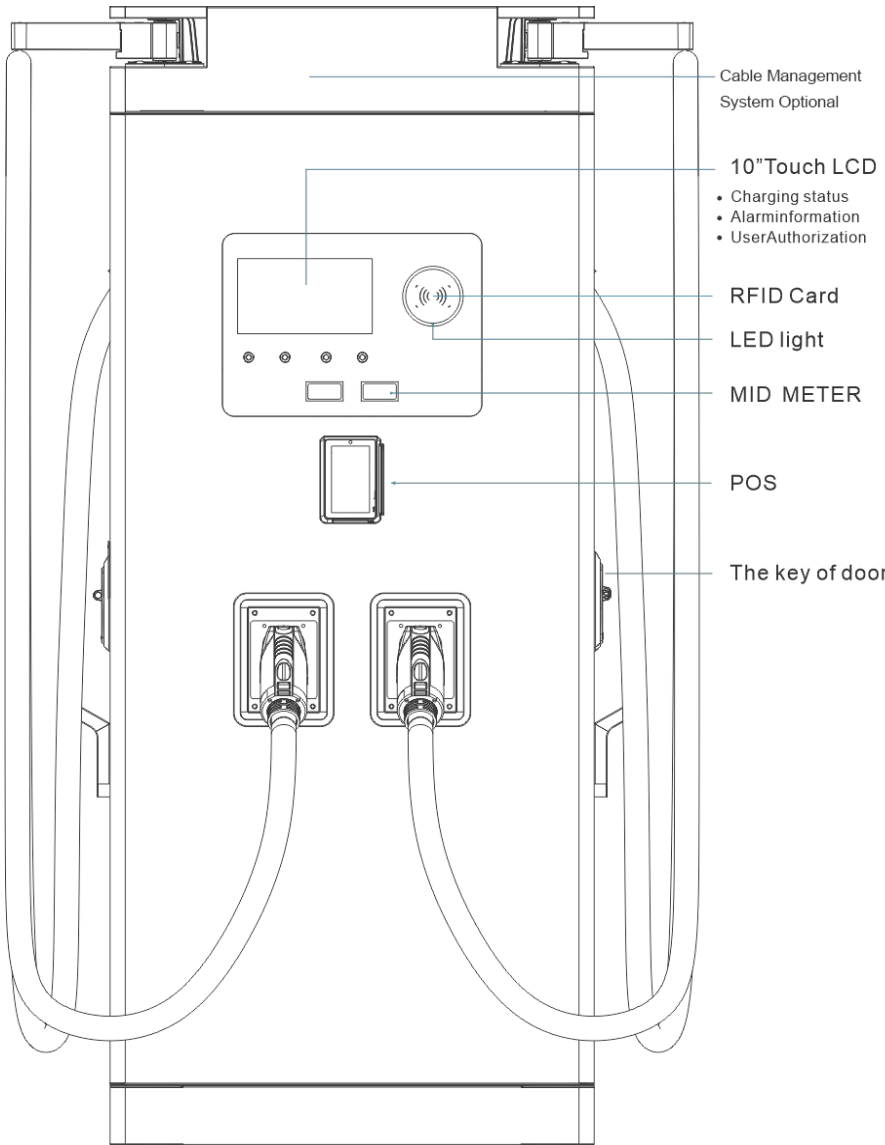

# 1.Specification

## 1.1 Product Specification

|              |                |                |                |                |                |                |                |                |
|--------------|----------------|----------------|----------------|----------------|----------------|----------------|----------------|----------------|
| <b>Model</b> | EVDC-F060-CC-Z | EVDC-F080-CC-Z | EVDC-F090-CC-Z | EVDC-F100-CC-Z | EVDC-F120-CC-Z | EVDC-F150-CC-Z | EVDC-F160-CC-Z | EVDC-F180-CC-Z |
|              | EVDC-F060-CC-M | EVDC-F080-CC-M | EVDC-F090-CC-M | EVDC-F100-CC-M | EVDC-F120-CC-M | EVDC-F150-CC-M | EVDC-F160-CC-M | EVDC-F180-CC-M |
|              | EVDC-F060-C-Z  | EVDC-F080-C-Z  | EVDC-F090-C-Z  | EVDC-F100-C-Z  | EVDC-F120-C-Z  | EVDC-F150-C-Z  | EVDC-F160-C-Z  | EVDC-F180-C-Z  |
|              | EVDC-F060-C-M  | EVDC-F080-C-M  | EVDC-F090-C-M  | EVDC-F100-C-M  | EVDC-F120-C-M  | EVDC-F150-C-M  | EVDC-F160-C-M  | EVDC-F180-C-M  |

### Technical features

|                             |                                                                                                                                  |        |        |        |        |        |        |        |
|-----------------------------|----------------------------------------------------------------------------------------------------------------------------------|--------|--------|--------|--------|--------|--------|--------|
| <b>Max Power</b>            | 60KW                                                                                                                             | 80KW   | 90KW   | 100KW  | 120KW  | 150KW  | 160KW  | 180KW  |
| <b>Input Voltage</b>        | 400VAC±10%-50/60Hz-3P+N+PE                                                                                                       |        |        |        |        |        |        |        |
| <b>Input Current</b>        | 91A                                                                                                                              | 122A   | 137A   | 152A   | 182A   | 228A   | 243A   | 274A   |
| <b>Power factor</b>         | ≥0.98                                                                                                                            |        |        |        |        |        |        |        |
| <b>Efficiency</b>           | >95%                                                                                                                             |        |        |        |        |        |        |        |
| <b>Overvoltage category</b> | III                                                                                                                              |        |        |        |        |        |        |        |
| <b>Pollution degree</b>     | Level 1                                                                                                                          |        |        |        |        |        |        |        |
| <b>Output voltage range</b> | 200-1000VDC                                                                                                                      |        |        |        |        |        |        |        |
| <b>Output current range</b> | 0-200A                                                                                                                           | 0-200A | 0-250A | 0-250A | 0-250A | 0-250A | 0-250A | 0-300A |
| <b>Communication</b>        | ISO15118 / DIN70121(between charger & vehicle) Ethernet/4G/OCPP 1.6J(WSS)                                                        |        |        |        |        |        |        |        |
| <b>User interface</b>       | LCD10.1/ 12.1 inch Touch Screen                                                                                                  |        |        |        |        |        |        |        |
| <b>Versatility</b>          | IEC61851/IEC62196/ISO1511/DIN70121/EN61000-6-4:2007                                                                              |        |        |        |        |        |        |        |
| <b>Security design</b>      | Over/under voltage protection, overload protection, current leakage protection, grounding protection,lightening surge protection |        |        |        |        |        |        |        |
| <b>DC Plugs</b>             | Cable 3.5M/5M/7M                                                                                                                 |        |        |        |        |        |        |        |
| <b>Energy Meter</b>         | CE certified                                                                                                                     |        |        |        |        |        |        |        |
| <b>MCCB</b>                 | Type A RCD(optional)                                                                                                             |        |        |        |        |        |        |        |
| <b>Load balancing</b>       | Load balancing device and CT(optional)                                                                                           |        |        |        |        |        |        |        |

### Physicalproperties

|                              |                         |       |       |       |       |       |       |  |
|------------------------------|-------------------------|-------|-------|-------|-------|-------|-------|--|
| <b>Warranty</b>              | 2 years                 |       |       |       |       |       |       |  |
| <b>Cooling</b>               | Air cooled              |       |       |       |       |       |       |  |
| <b>IP/IK Level</b>           | IP55/IK08               |       |       |       |       |       |       |  |
| <b>Sound noise</b>           | <70DB in all directions |       |       |       |       |       |       |  |
| <b>Operating temperature</b> | -30℃ to +50℃            |       |       |       |       |       |       |  |
| <b>Humidity</b>              | Max.95%(non-regulating) |       |       |       |       |       |       |  |
| <b>Dimensions</b>            | 1902*800*750 mm         |       |       |       |       |       |       |  |
| <b>Package Dimension</b>     | 2026*1200*930mm         |       |       |       |       |       |       |  |
| <b>Net Weight</b>            | 285Kg                   | 295Kg | 335Kg | 335Kg | 335Kg | 350Kg | 350Kg |  |
| <b>GrossWeight</b>           | 345Kg                   | 345Kg | 390Kg | 390Kg | 390Kg | 415Kg | 415Kg |  |

|              |                |                |                |                |                |                |                |
|--------------|----------------|----------------|----------------|----------------|----------------|----------------|----------------|
| <b>Model</b> | EVDC-F200-CC-Z | EVDC-F220-CC-Z | EVDC-F240-CC-Z | EVDC-F260-CC-Z | EVDC-F280-CC-Z | EVDC-F300-CC-Z | EVDC-F320-CC-Z |
|              | EVDC-F200-CC-M | EVDC-F220-CC-M | EVDC-F240-CC-M | EVDC-F260-CC-M | EVDC-F280-CC-M | EVDC-F300-CC-M | EVDC-F320-CC-M |
|              | EVDC-F200-C-Z  | EVDC-F220-C-Z  | EVDC-F240-C-Z  | EVDC-F260-C-Z  | EVDC-F280-C-Z  | EVDC-F300-C-Z  | EVDC-F320-C-Z  |
|              | EVDC-F200-C-M  | EVDC-F220-C-M  | EVDC-F240-C-M  | EVDC-F260-C-M  | EVDC-F280-C-M  | EVDC-F300-C-M  | EVDC-F320-C-M  |

## Technical features

|                             |                                                                                                                                  |        |        |        |        |        |        |
|-----------------------------|----------------------------------------------------------------------------------------------------------------------------------|--------|--------|--------|--------|--------|--------|
| <b>Max Power</b>            | 200KW                                                                                                                            | 220KW  | 240KW  | 260KW  | 280KW  | 300KW  | 320KW  |
| <b>Input Voltage</b>        | 400VAC±10%-50/60Hz-3P+N+PE                                                                                                       |        |        |        |        |        |        |
| <b>Input Current</b>        | 304A                                                                                                                             | 334A   | 365A   | 395A   | 426A   | 456A   | 485A   |
| <b>Power factor</b>         | ≥0.98                                                                                                                            |        |        |        |        |        |        |
| <b>Efficiency</b>           | >95%                                                                                                                             |        |        |        |        |        |        |
| <b>Overvoltage category</b> | III                                                                                                                              |        |        |        |        |        |        |
| <b>Pollution degree</b>     | Level 1                                                                                                                          |        |        |        |        |        |        |
| <b>Output voltage range</b> | 200-1000VDC                                                                                                                      |        |        |        |        |        |        |
| <b>Output current range</b> | 0-300A                                                                                                                           | 0-300A | 0-300A | 0-300A | 0-300A | 0-300A | 0-300A |
| <b>Communication</b>        | ISO15118 / DIN70121(between charger & vehicle) Ethernet/4G/OCPP 1.6J(WSS)                                                        |        |        |        |        |        |        |
| <b>User interface</b>       | LCD10.1/ 12.1 inch Touch Screen                                                                                                  |        |        |        |        |        |        |
| <b>Versatility</b>          | IEC61851/IEC62196/ISO15111/DIN70121/EN61000-6-4:2007                                                                             |        |        |        |        |        |        |
| <b>Security design</b>      | Over/under voltage protection, overload protection, current leakage protection, grounding protection, lightning surge protection |        |        |        |        |        |        |
| <b>DC Plugs</b>             | Cable 3.5M/5M/7M                                                                                                                 |        |        |        |        |        |        |
| <b>Energy Meter</b>         | CE certified                                                                                                                     |        |        |        |        |        |        |
| <b>MCCB</b>                 | Type A RCD(optional)                                                                                                             |        |        |        |        |        |        |
| <b>Load balancing</b>       | Load balancing device and CT(optional)                                                                                           |        |        |        |        |        |        |

## Physical properties

|                              |                         |       |       |         |         |         |         |
|------------------------------|-------------------------|-------|-------|---------|---------|---------|---------|
| <b>Warranty</b>              | 2 years                 |       |       |         |         |         |         |
| <b>Cooling</b>               | Air cooled              |       |       |         |         |         |         |
| <b>IP Level</b>              | IP55/IK08               |       |       |         |         |         |         |
| <b>Sound noise</b>           | <70DB in all directions |       |       |         |         |         |         |
| <b>Operating temperature</b> | -30℃ to +50℃            |       |       |         |         |         |         |
| <b>Humidity</b>              | Max.95%(non-regulating) |       |       |         |         |         |         |
| <b>Dimensions</b>            | 1902*800*750 mm         |       |       |         |         |         |         |
| <b>Package Dimension</b>     | 2026*1200*930mm         |       |       |         |         |         |         |
| <b>Net Weight</b>            | 425Kg                   | 425Kg | 445Kg | 471.8Kg | 471.8Kg | 471.8Kg | 471.8Kg |
| <b>GrossWeight</b>           | 475Kg                   | 475Kg | 495Kg | 530.0Kg | 530.0Kg | 530.0Kg | 530.0Kg |

## 1.2 Dimmensions (Unit: mm)

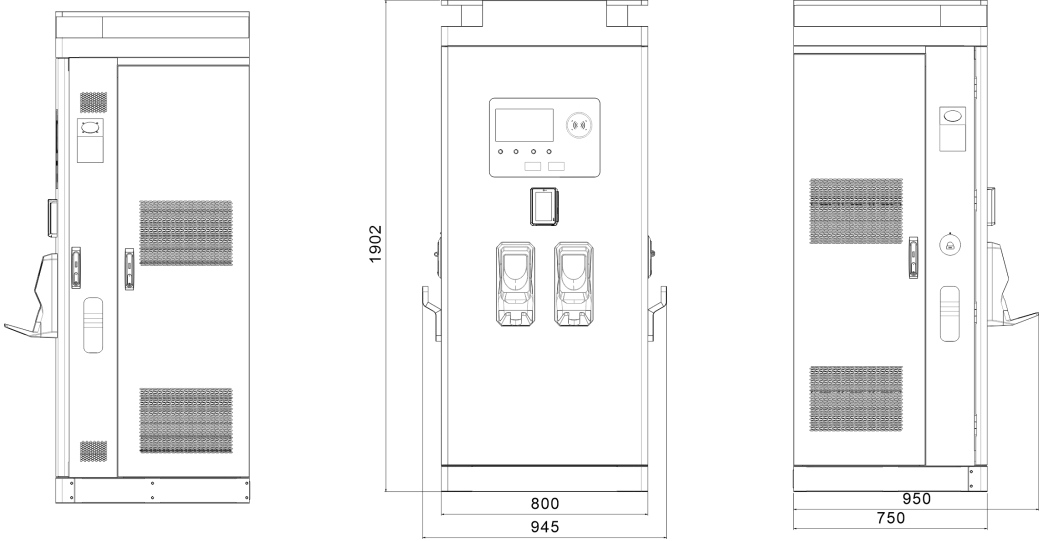

## 2. Installation Instruction

### 2.1 Before Installation

- Read all the instructions before using and installing this product.
- Do not use this product if power cable or charging cable have any damage.
- Do not use this product if the enclosure or charging connector are broken or open or if there is damage.
- Do not put any tool, material, finger or other body part into the charging connector or EV connector.



**Warning:** The product should be installed only by a licensed contractor and/or licensed technician in accordance with all building codes, electrical codes and safety standards.



**Warning:** The product should be inspected by a qualified installer prior to initial use. Under no circumstances will compliance with the information in this manual relieve user of his /her responsibilities to comply with all applicable codes and safety standards.

- Power feed must be 3 Phase Wye configuration with TN(-S)/ IT/ TT grounding systems.
- In the installation of TN(-S) system: the neutral (N) and the PE of the power distribution are directly connected to the earth. The PE of the charger equipment is directly connected to the PE of power distribution and separate conductor for PE and neutral (N).
- In the installation of IT system: the neutral of the power distribution system is isolated from the earth. The PE of the charger equipment is isolated to the PE of power distribution to the earth.
- In the installation of TT system: the neutral (N) and the PE of the power distribution are directly connected to the earth. The PE of the charger equipment is isolated to the PE of power distribution to the earth.
- The capacity of power supply should be higher than 33.0kVA in order to function correctly.
- The product should be installed in free air area and keep at least 30cm clearance distance to all air vent of the product.
- Need sufficient space for product installation and maintenance, please keep not less than 60cm clearance distance from all around the product. The product should be installed in free air area and keep at least 30cm clearance distance to all air vent of the product

## 2.2 Grounding and Safety Requirement

- The product must be connected to a grounded, metal, permanent wiring system. Connections shall comply with all applicable electrical codes.
- Ensure no power is connected at all times when installing, servicing, or maintaining the charger.
- Use appropriate protection when connecting to main power distribution network.
- Use appropriate tools for each task.



**CAUTION:** The disconnect switch for each ungrounded conductor of AC input shall be provided by installation contractor or technician.



**CAUTION:** A cord extension set or second cable assembly shall not be used in addition to the cable assembly for connection of the EV to the EV.

## 2.3 Service Wiring

- Ground Connection

Always connect the Neutral at the service to Earth Ground. If ground is not provided by the electrical service then a grounding stake must be installed nearby. The grounding stake must be connected to the ground bar in the main breaker panel and Neutral connected to Ground at that point.

- 400Vac(Line to Line) Three-Phase

**CAUTION!**



This is feed from Wye-connection power grid, the Wall Mount DC Fast Charger can connect to L1, L2 or L3, and Neutral. Earth ground must be connected to neutral at only one point, usually at the breaker panel.

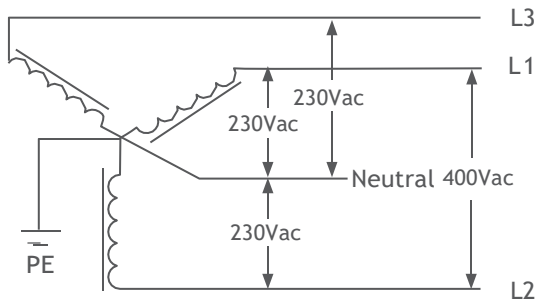

400V Three-Phase Wiring Connection



**DANGERS**

Be Aware of High Voltage!



**WARNING!**

Earth Connection is Essential!

## 2.4 Unpack the charger



**WARNING!**

Charger weight might >350Kg!  
Be careful during unpack process.

**STEP 1.**



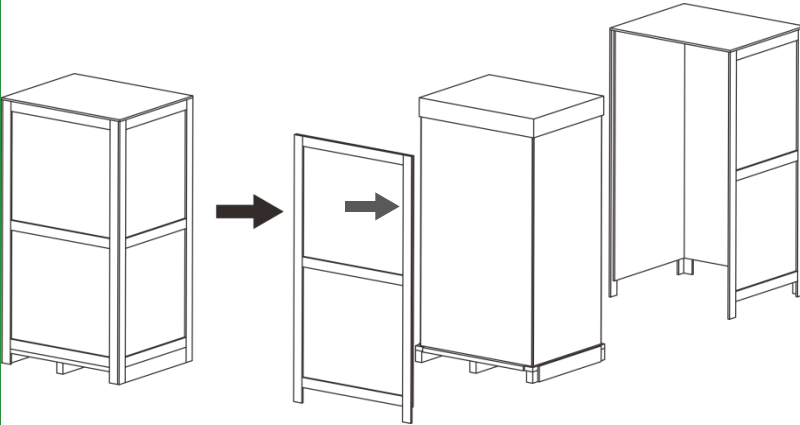



Remove the surrounding boards

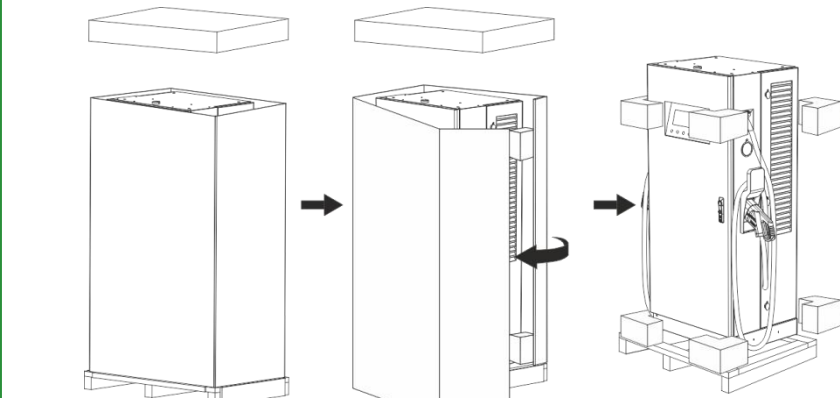

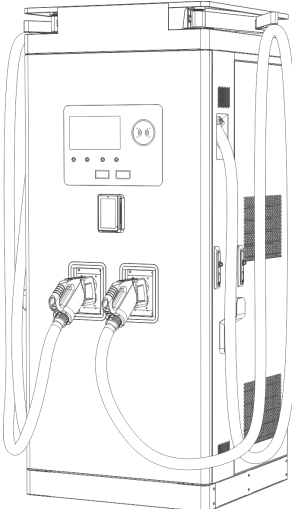
**STEP 2.**

Remove the packaging film and the paper cover. Accessories are packed in a carton.



|                                                                                   |                                                                                   |                                                                                   |                                                                                   |
|-----------------------------------------------------------------------------------|-----------------------------------------------------------------------------------|-----------------------------------------------------------------------------------|-----------------------------------------------------------------------------------|
|  |  |  |  |
|                                                                                   | <p>User Manual<br/>(x1)</p>                                                       | <p>card reader<br/>(x1)</p>                                                       | <p>Expansion bolt (x4)<br/>M12*100mm</p>                                          |
|                                                                                   |  |  |  |
| <p>DC Charger</p>                                                                 | <p>RFID CARD (x2)</p>                                                             | <p>Key (x4)</p>                                                                   | <p>SD card(x1)</p>                                                                |

## 2.5 Recommended Tools for Installation and Inspection

### 2.5.1 Recommended Tools for Installation

| Type                              | Description                                          |
|-----------------------------------|------------------------------------------------------|
| Philips Screwdriver               | No. 2 and 3                                          |
| Shifting Wrench                   | 8" (24mm)                                            |
| Ball-Head Hex Key                 | 2.5mm and 5mm                                        |
| Socket Screwdriver                | No. 8 ,10 and 17                                     |
| Electrical Tape                   | Black / 15mm Width                                   |
| <b>AC Input Cable of 60KW</b>     | <b>35mm<sup>2</sup> Cable x 5 (L1,L2,L3,N,PE)</b>    |
| <b>AC Input Cable of 80KW</b>     | <b>50mm<sup>2</sup> Cable x 5 (L1,L2,L3,N,PE)</b>    |
| <b>AC Input Cable of 120KW</b>    | <b>95mm<sup>2</sup> Cable x 5 (L1,L2,L3,N,PE)</b>    |
| <b>AC Input Cable of 160KW</b>    | <b>2x95mm<sup>2</sup> Cable x 5 (L1,L2,L3,N,PE)</b>  |
| <b>AC Input Cable of 180KW</b>    | <b>185mm<sup>2</sup> Cable x 5 (L1,L2,L3,N,PE)</b>   |
| <b>AC Input Cable of 240KW</b>    | <b>2x150mm<sup>2</sup> Cable x 5 (L1,L2,L3,N,PE)</b> |
| <b>AC Input Cable of 320KW</b>    | <b>2x185mm<sup>2</sup> Cable x 5 (L1,L2,L3,N,PE)</b> |
| Crimping Pliers for Ring Terminal | Applied for 100- 185mm <sup>2</sup>                  |
| Machine Drill                     |                                                      |
| Wire Cutters                      |                                                      |
| Level Ruler                       |                                                      |

### 2.5.2 Recommended Tools for Inspection & Commissioning

| Type                      | Description               |
|---------------------------|---------------------------|
| EV or EV Simulator        | Meet CCS2 standard        |
| Multiple Meter            | 1000V                     |
| Current Probe             | 600Amp                    |
| RFID Authorized Card      |                           |
| RFID No Valid Card        |                           |
| Door Key                  |                           |
| Needle-Nose Plier         |                           |
| Laptop or PC & CAT6 cable | For Charger Configuration |

## 2.6 Installation Procedure

### STEP 1.

1. Build 120mm x 1200mm x 300mm concrete base on the level to stand charger in advance.
2. Implant AC input cable conduit less than  $\Phi 102\text{mm}$  (eg. 4" PVC conduit), and SFTP Ethernet cable conduit less than  $\Phi 34\text{mm}$  (eg. 1 1/4" PVC conduit).
3. And implant 4 pcs of M12 screw stick out the concrete base for 40 mm (1.57") to fix the charger. The positioning of these 4 pcs of M12 screws should be within  $\pm 2\text{ mm}$  (0.08") in short axis,  $\pm 8\text{ mm}$  (0.32") in long axis according to screw holes of charger.
4. To fit this positioning requirement, a steel plate fixture be suggested. Please create the fixture by the following drawing or order this fixture from your vendor.
5. The other way to fix the charger on concrete base is install 2 of L-brackets accessories outside of charger and drill the screw holes ( $\Phi 16\text{ mm}$  (0.63")) on the cement base as drawing below.

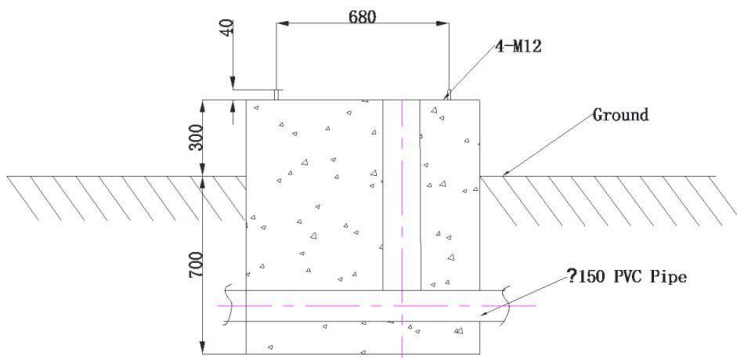
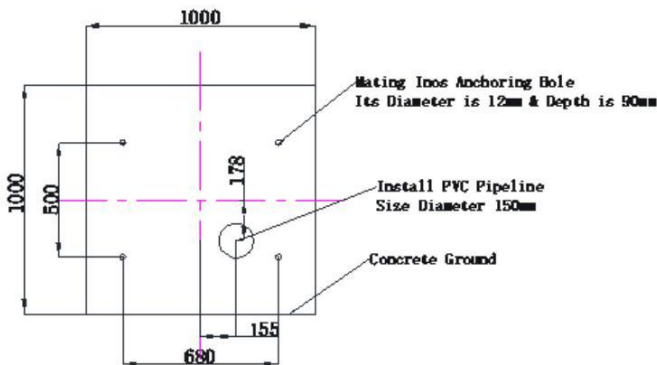

## STEP 2.

1. Lift the charger on concrete base, pull the input cable through bottom hole of charger; fasten 8 pcs of M12 screw nuts and 4 pcs M12 washers on 4 pcs of M12 screw of concrete base (2 nuts for each screw) to secure the chargers. Then fix the base cover(in the accessory pack) in charger base.

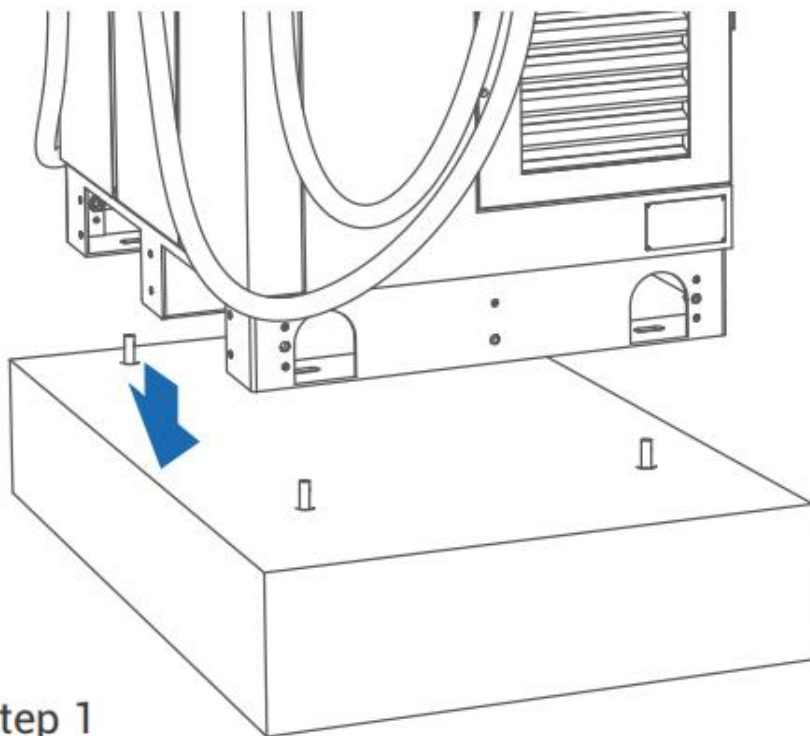

Step 1

**STEP 3.**

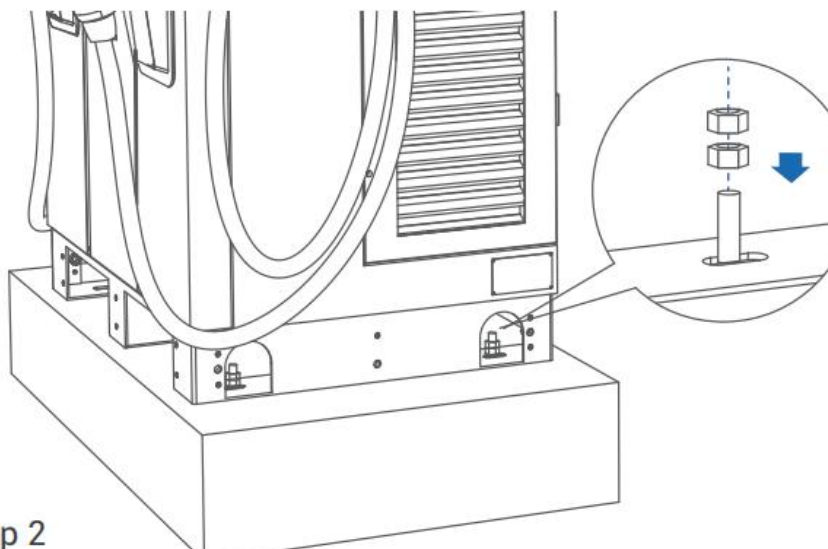

Step 2

**STEP 4.**

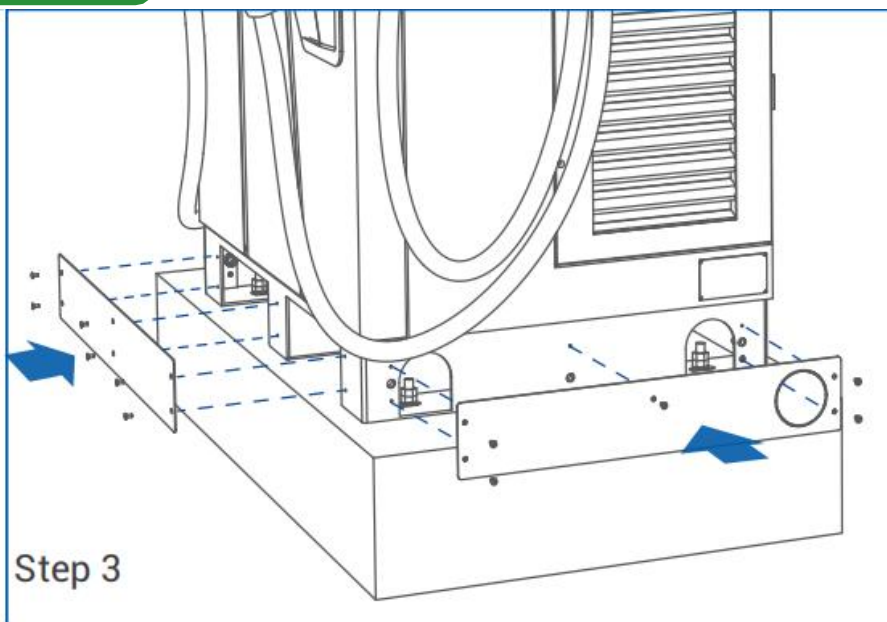

Step 3

# Installing the AC Input Connect

## STEP 5.

Connect L1, L2, L3 and N of AC power to 4P terminal. Fasten each wire with proper screw and torque number- 120Kgf.cm/5-15 secs. Connect the PE wire (green with yellow) to Grounding position of Charger and torque number- 220Kgf.cm. Keep proper length of each wires then fasten cable grand.

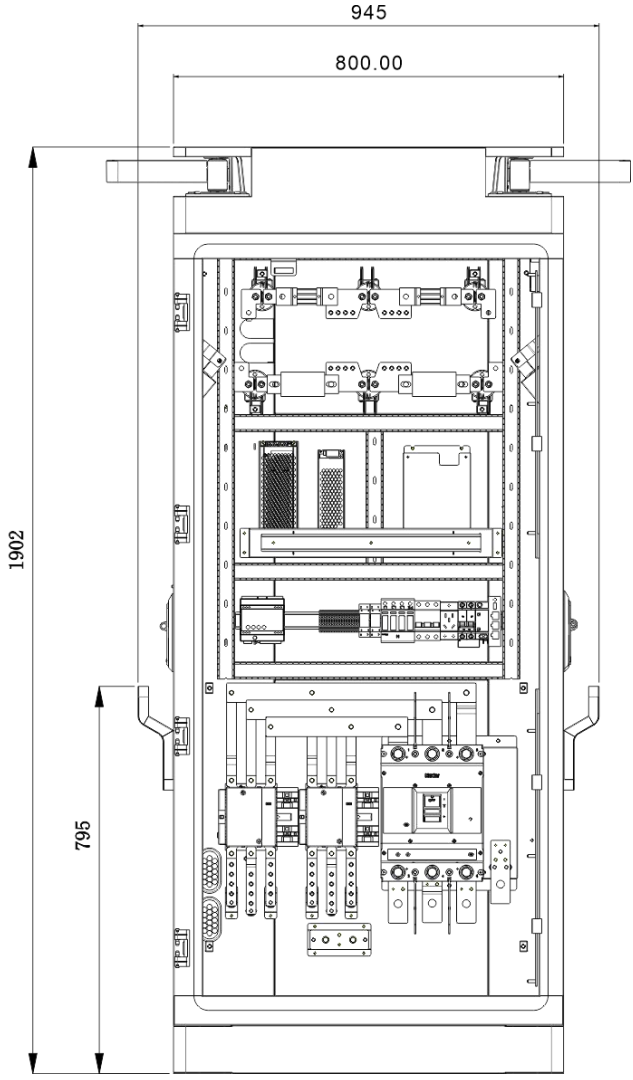

## 2.7 Installation Inspection & Commissioning

### 2.7.1 Environmental Check

| Item                     | Status | Remark                        |
|--------------------------|--------|-------------------------------|
| Ambient Temperature      |        |                               |
| Ambient Humidity         |        |                               |
| Sunshade                 |        | Recommended but not required. |
| Rain Canopy              |        | Recommended but not required. |
| Air Circulation / Drafty |        |                               |
| Dust Level               |        |                               |
| Anti-Vandalism Measures  |        |                               |

### 2.7.2 External Infrastructure Readiness & Check

| Item                            | Status | Remark                                                        |
|---------------------------------|--------|---------------------------------------------------------------|
| Input Wirings & Terminals       |        | Type/ Length/ Cross Section                                   |
| Key & Lock of Cabinet Door      |        |                                                               |
| Fixing Screws                   |        | Type / No                                                     |
| No Fuse Breaker (NFB)           |        | Notice:<br>Current rating of NFB shall be higher than 63 Amp  |
| Residual Current Device (RCD)   |        | Notice:<br>Maximum RCD residual current shall not exceed 30mA |
| Input Electricity Capacity      |        |                                                               |
| Input Electricity Configuration |        | Wye                                                           |
| Grounding Resistance            |        | <50Ω                                                          |
| Grounding System                |        |                                                               |
| Input Voltage & Frequency       |        |                                                               |
| Network Connection & Quality    |        | LAN/ Wi-Fi/4G                                                 |

### 2.7.3 EV Check - Static (Non-Powered)

| Item                        | Status | Remark |
|-----------------------------|--------|--------|
| Outlook                     |        |        |
| Labeling & Warning Signs    |        |        |
| Package (Accessory) List    |        |        |
| Robustness of Input Wirings |        |        |

### 2.7.3 EV Check - Power On

| Item                           | Status | Remark |
|--------------------------------|--------|--------|
| Screen On                      |        |        |
| Acoustic Noise                 |        |        |
| Screen Display & Function      |        |        |
| Time Display Correctly         |        |        |
| Network Connection Quality     |        |        |
| Cooling Fans Operation & Noise |        |        |
| Led Status Indication          |        |        |
| EV Setting                     |        |        |
| Function of Engineer Mode      |        |        |
| Version of H.W. & F.W.         |        |        |
| Remote Control & Monitoring    |        |        |
| Backend Server Connection      |        |        |

### 1.2.1 EV Check-Charging

| Item                             | Status | Remark |
|----------------------------------|--------|--------|
| User Authorization -RFID         |        |        |
| User Authorization -QR Code      |        |        |
| User Authorization -Others.      |        |        |
| Waiting Time of Connection Check |        |        |
| Reading of Each Display Item     |        |        |
| Full Charge Test                 |        |        |
| Function of Electronic Lock      |        |        |
| Reading of Engineer Mode         |        |        |
| Airflow & Noise of Cooling Fan   |        |        |
| Charging Record ( log ) Upload   |        |        |
| Remote Control & Monitoring      |        |        |

### 1.2.2 EV Check -System Power Button

| Item                  | Status | Remark |
|-----------------------|--------|--------|
| Emergency Stop Button |        |        |

# 2. Network Setting

## 2.1 4G Network Setting

On the Network Parameters page, set URL and the 4G card APN and save the settings (If the 4G card you purchased has an APN username and password please enter the corresponding username and password) . Then, power off the device, insert the 4G card into the motherboard slot, and replace the 4G module. And power on device.

The screenshot shows the 'Management' screen with a central circular navigation hub. The 'Net Parameters' option is highlighted with a red rectangular box. Other menu items include 'Charger Information', 'Fault Details', 'Charging record', 'System Parameters', and 'Protection Parameters'. A green circular 'Back' button is located in the bottom right corner.

---

The 'Net Parameters' configuration page is displayed. The '4G APN' field is highlighted with a red box and contains the value 'ctnet'. Other fields include 'Server URL1', 'Server URL2', 'Charger IP', 'Subnet mask', 'Gateway', 'DNS', 'MAC Addr', 'DHCP', 'WIFI key', 'WIFI SSID', '4G user name', and '4G user pwd'. A green 'Saving' button and a green circular 'BACK' button are at the bottom right.

|              |                                        |                     |
|--------------|----------------------------------------|---------------------|
| Server URL1: | ws://ocpp.ying-power.com:33033/ocpp/ws |                     |
| Server URL2: |                                        |                     |
| Charger IP:  | 192 · 168 · 2 · 5                      | WIFI key: 12345678  |
| Subnet mask: | · · ·                                  | WIFI SSID: ZKXNY    |
| Gateway:     | · · ·                                  | 4G user name:       |
| DNS:         | · · ·                                  | 4G user pwd:        |
| MAC Addr:    |                                        | Authentication key: |
| 4G APN:      | ctnet                                  |                     |
| DHCP:        | 1                                      |                     |

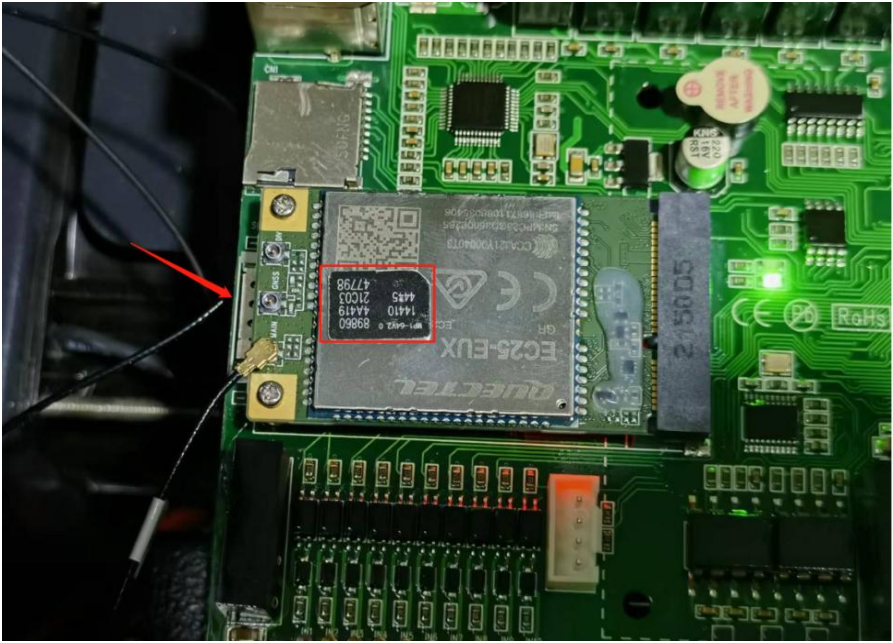

## Replace WiFi module



17 MAY 2022 / 14:11:10

V01

2442200101

**A**



Connect vehicle to start

Available

**B**



Connect vehicle to start

Available

SETTING

If the network is working, the 4G signal icon will be displayed

## 2.2 Wi-Fi Network Setting

On the charging station display screen, start searching for the Settings - NetworkParameters page on the homepage, set URL and the WiFi SSID and WiFi KEY, then replace the WiFi module internally and restart the charging station:

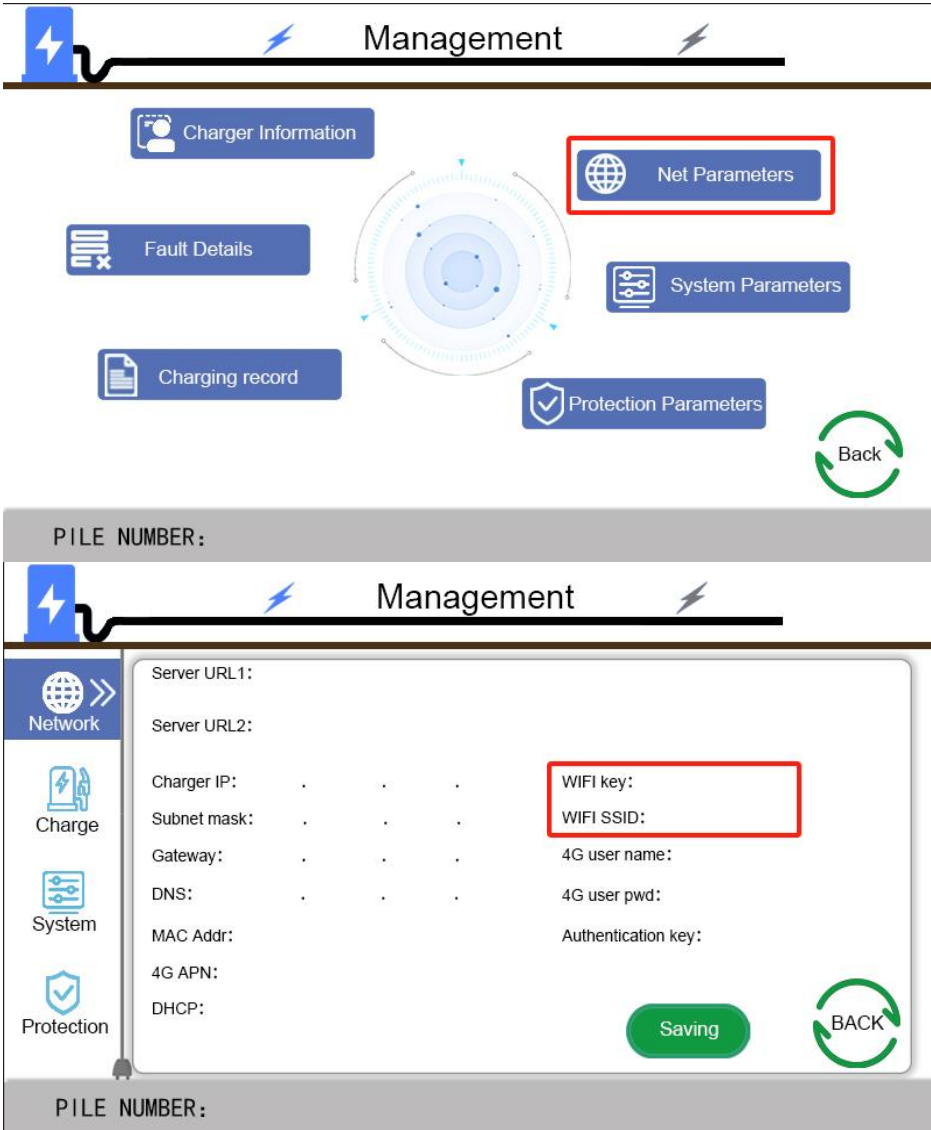



## Replace WiFi module



17 MAY 2022 / 14:11:10

V01

2442200101

**A**



Connect vehicle to start

Available

**B**



Connect vehicle to start

Available

SETTING 

If the network is working, the WIFI signal icon will be displayed

## 2.3 Ethernet DHCP Network Setting

On the Network Parameters page, set URL and the DHCP type to 1. Connect a network cable from the router to the RJ45 port on the motherboard, then restart the charging station.

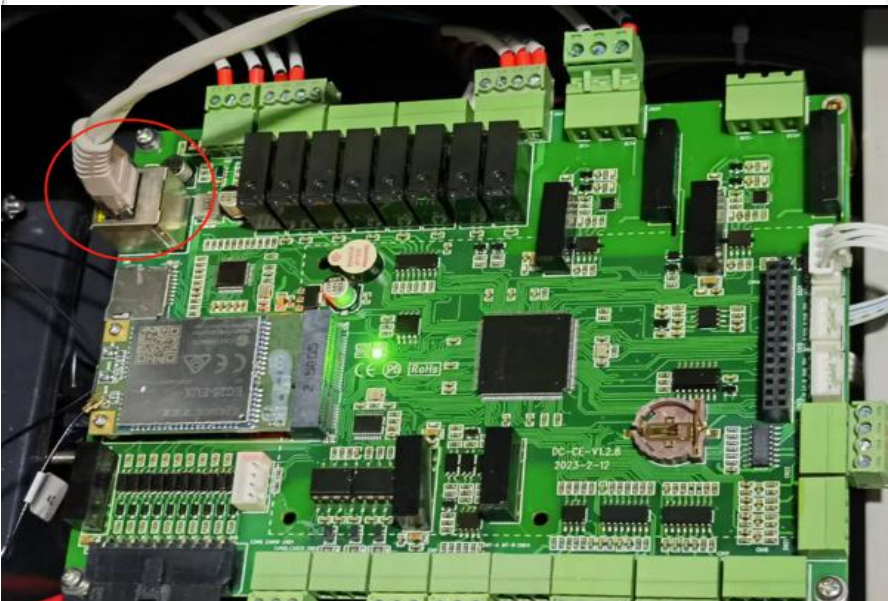
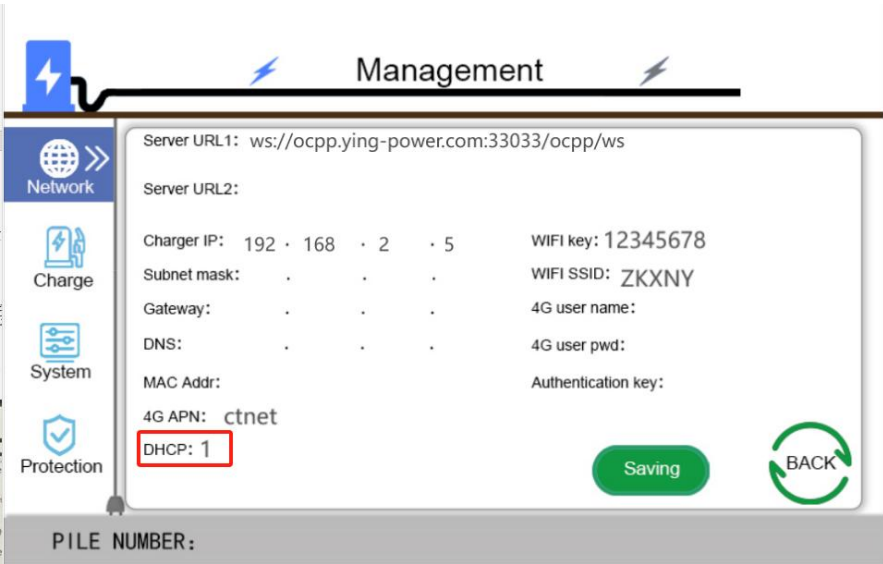

Connect the router via Ethernet cable



**A**



Connect vehicle to start

Available

**B**



Connect vehicle to start

Available

SETTING

If the network is working, the Wlan signal icon will be displayed

### 3. Operation Process

#### 3.1 RGB LED indicators

| Charger status     | LED performance    |
|--------------------|--------------------|
| Standby            | green blink        |
| plug in            | yellow             |
| swipe/punch a card | yellow             |
| charging           | Light green breath |
| Fault status       | Red flashing       |

#### 3.2 LCD indicators

the EMN series config a 7-inch LCD screen, which is mainly used to display various status information of the charging station.

##### ■ Icons or instructions in each display area

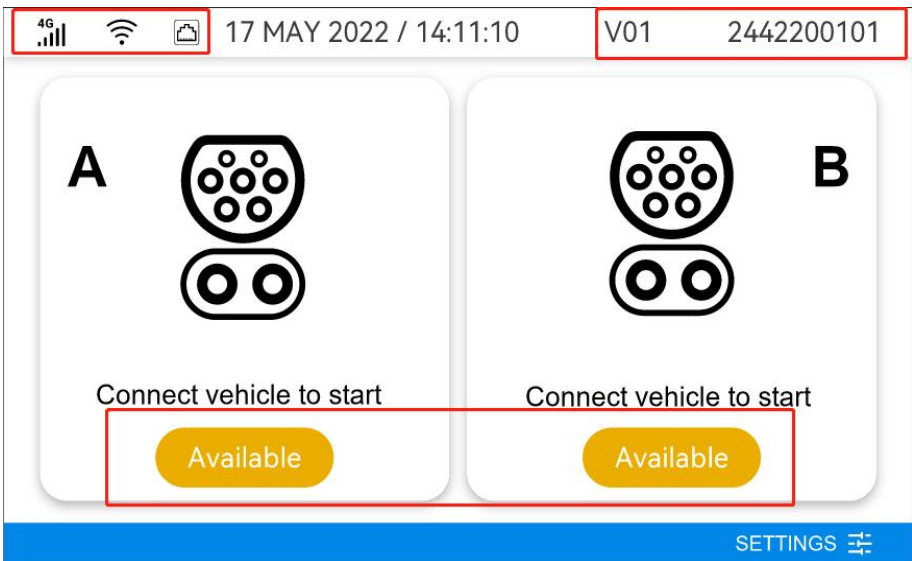





Fig. 1-2 Display of icons and instructions

In Fig. 1-2, there are three areas to display icons or instructions, with the specific meanings as follows:

| No. Area ①    | Icon                                                                              | Description                             |
|---------------|-----------------------------------------------------------------------------------|-----------------------------------------|
| 1             |  | Connected a network through 4G cellular |
| 2             |  | Connected a network through WIFI        |
| 3             |  | Connected a network through Ethernet    |
| <b>Area ②</b> |                                                                                   |                                         |
| 4             | Version                                                                           | Software version                        |
| 5             | SN                                                                                | Serial number of EV                     |
| <b>Area ③</b> |                                                                                   |                                         |
| 5             | status                                                                            | EV status information                   |
| <b>Area 4</b> |                                                                                   |                                         |
| 6             | Settings                                                                          | Set charging station parameters         |

■ As shown in Fig.1-3,1-4,1-5,1-6,the LCD screen displays 4 types picture in normal state.

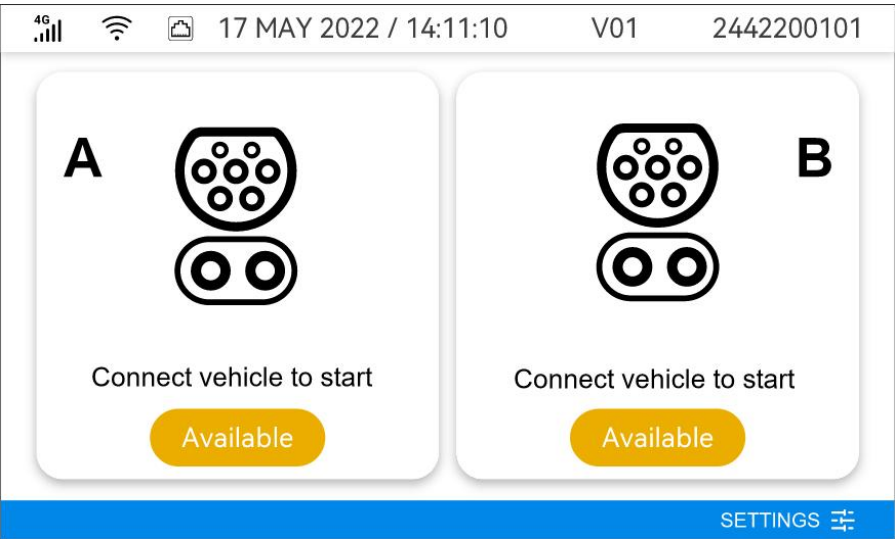

Fig. 6-3 Display of Preparing

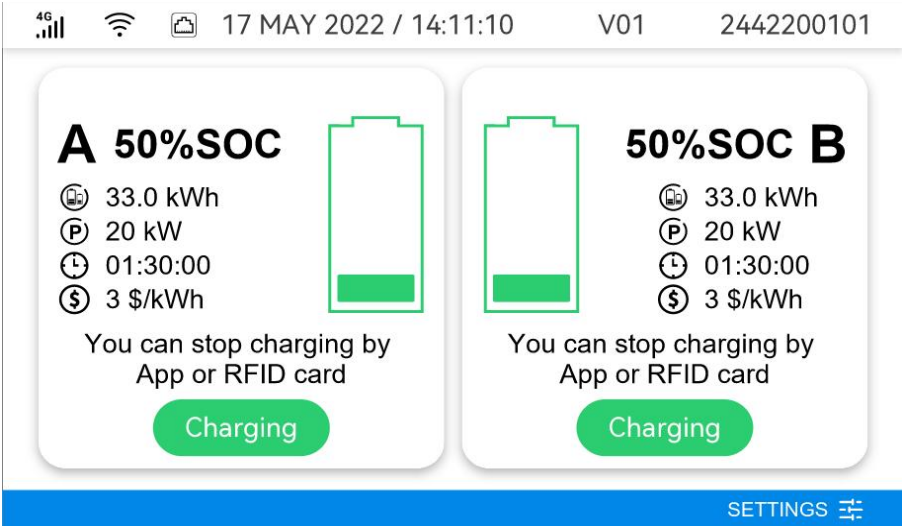

Fig. 6-4 Display of Charging

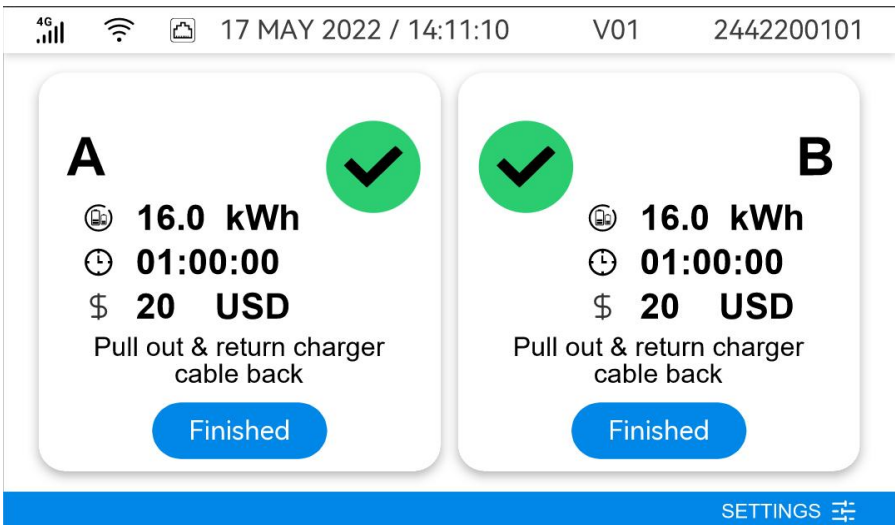

Fig. 6-5 Display of Finished

n Click the settings icon three times to enter the settings interface, the picture displayed on the LCD screen is shown in Fig. 6-6.

n Enter password: 1234

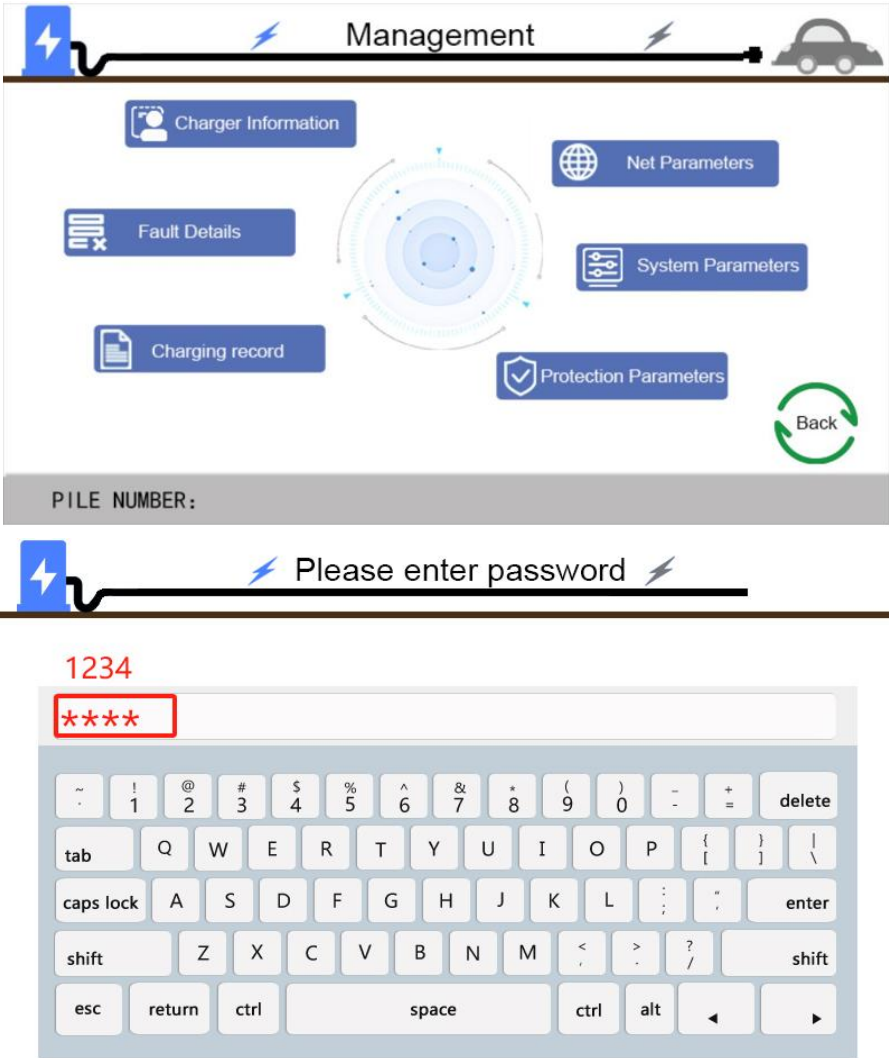

Fig. 6-6 Display of Management

n If the charging process fails or the equipment fails, the picture displayed on the LCD screen is shown in Fig. 6-7.

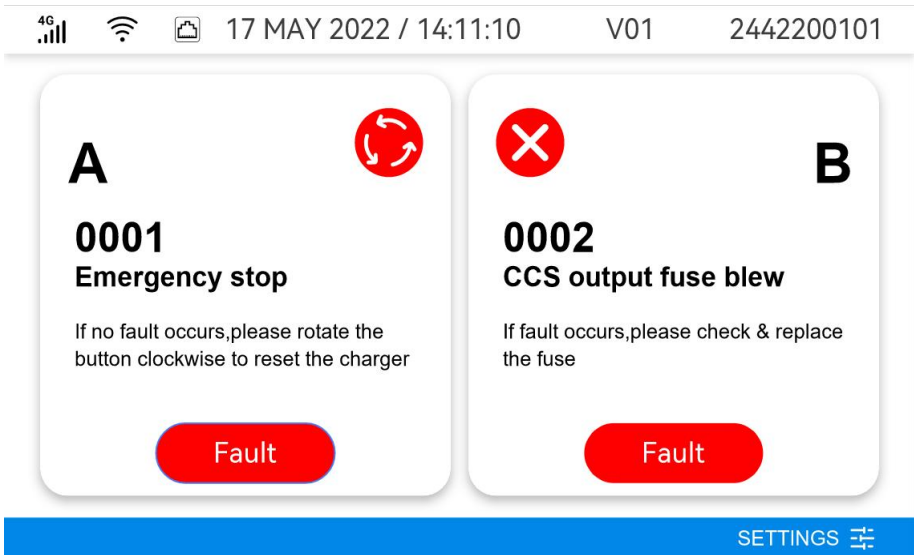

Fig. 6-7 Display of fault state

### 3.3 Troubleshooting

- Please follow the instruction in the table when errors occur during the charging process.
- Or please contact the DC Quick Charger provider for further instructions.
- If an emergency occurs push the Emergency Stop Button to stop charging immediately.

## 3.4 Status Codes

•For latest status code, please visit our website.

| Status Code | Description                              | Solution                                                                    |
|-------------|------------------------------------------|-----------------------------------------------------------------------------|
| 0001        | Emergency stop                           | If no fault occurs,please rotate the button clockwise to reset the charger. |
| 0002        | CCS output fuse blew                     | If fault occurs,please check&replace the fuse.                              |
| 0003        | AC input contactor 1 welding             | If fault occurs,please check&replace the contactor.                         |
| 0004        | CCS output relay welding                 | If fault occurs,please check&replace the Relay.                             |
| 0005        | CCS connector temperature sensor broken  | If fault occurs,please check&replace the sensor.                            |
| 0006        | Relay control module /smart box broken   | If fault occurs,please check&replace the Relay control module.              |
| 0007        | CCS Power module fault                   | If fault occurs,please replace the CCS Power module.                        |
| 0008        | Maximum Output Current setup error       | If fault occurs,please reset the correct value.                             |
| 0009        | Maximum Output Voltage setup error       | If fault occurs,please reset the correct value.                             |
| 0010        | BLE module broken                        | If fault occurs,please replace the BLE module.                              |
| 0011        | 4G module broken                         | If fault occurs,please replace the 4G module.                               |
| 0012        | Ethernet BLE module broken               | If fault occurs,please replace the Ethernet BLE.                            |
| 0013        | wifi module broken                       | If fault occurs,please replace the wifi module.                             |
| 0014        | CCS connector OTP                        | If fault occurs,please check&reset the OTP value.                           |
| 0015        | SPD trip                                 | If fault occurs,please replace the SPD Module.                              |
| 0016        | CCS ground fault detection timeout (GFD) | If fault occurs,please check the Ground line.                               |
| 0017        | RFID module communication fail           | If fault occurs,please check Communication line with RFID.                  |
| 0018        | Power module communication fail          | If fault occurs,please check can line with power module.                    |
| 0019        | Door open                                | If fault occurs,please closed the door &recharge with vehicle.              |
| 0020        | System fan decay                         | If fault occurs,please replace the fan.                                     |
| 0021        | AC Ground Fault                          | If fault occurs,please check the Ground line.                               |
| 0022        | CCS EV communication Fail                | If fault occurs,please check Connecting wire with vehicle.                  |

## 4. Maintenance

### 4.1 General Maintenance

- The DC Fast Charger is cooled by forced air. Please keep charger in a ventilated location and do not block the air vents of the DC Fast Charger .
- Please clean or replace the air filters regularly to ensure the DC Fast Charger works properly.
- Clean the DC fast Charger at least three times a year, keep the exterior clean at all times.
- Clean the outside of the cabinet with damp cloth or wet cotton towel, only use low-pressure tap water and cleaning agents with PH level between 6 to 8.
- Do not apply high-pressure water jets.
- Do not use cleaning agents with abrasive components and do not use abrasive tools. Improper cleaning agents might spoiled coating, painting, surface, brightness and durability of all exterior parts.
- If there is water intruding into the DC Fast Charger then please cut off the power source immediately and contact the DC Fast Charger provider for repair.
- Please make sure the charging connector is returned to the holder of the charging connector after charging to prevent damage.
- If there is damage to the charging connector, charging cable or holder of the charging connector then please contact the DC Fast Charger provider.
- When using the DC Fast Charger please handle properly. Do not strike or scrape the cabinet or touchscreen.
- If the enclosure or touch screen is broken, cracked, open or shows any other indication of damage then please contact the Standalone DC Fast Charger provider.



**WARNING:** Danger of electrical shock or injury. Turn OFF power at the panelboard or load center before working on the equipment or removing any component. Do not remove circuit protective devices or any other component until the power is turned OFF.

- Disconnect electrical power to the DC Fast Charger before any maintenance work to ensure it is separated from the supply of AC mains. Failure to do so may cause physical injury or damage to the electrical system and charging unit.

Note:

- Before switching off main breaker to begin maintenance, please record the status code number on the LCD monitor.
- After switching off the key switch the circuit before the main terminal is still hazardous. Only visual inspection can be operated.
- Maintenance of the DC Fast Charger shall be conducted only by a qualified technician.
- After opening the front door of the DC Fast Charger, turn off the main breaker and auxiliary breaker before any maintenance work.
- Replace the ventilation filter every six to twelve months.

## Limited Product Warranty

The warranty period for this charger is two years.

Any spare parts provided by Technology and used as replacements for repair are covered by a five-year guarantee.

Replacement and repair parts manufactured by alternative manufacturers to those on the maintenance parts are only allowed if authorized by .

Warranty Exclusions:

- Damage or rendered non-functional as a result of power surges, lighting, earthquake, fire
- flood, pest damage, abuse, accident, misuse, negligence or failure to maintain the product or other event beyond 's reasonable control or not arising from normal operating condition.
- Cosmetic or superficial defect, dents, marks or scratches after use.
- Components which are separate from the product, ancillary equipment and consumables, such as door key, RFID card, air filter, fuse, cable, wires and connectors.
- Damage as a result of modifications, alterations or disassembling which were not pre-authorized in writing by .
- Damage due to the failure to observe the applicable safety regulations governing the proper use of the product.
- Installed or operated not in strict conformance with the documentation, including without limitation, not ensuring sufficient ventilation for the product as described in installation instruction.

If a defect in the product arises and valid claim is received within the warranty period, your sole and exclusive remedy will be for , at its sole discretion and to extent permitted by law, to

1. Repair the defect in the product at no charge, using new or refurbished parts.
2. Exchange the product with new or refurbished product that is functionally equivalent to the original product.

Any remedy hardware product will be warranted for the remainder of the original warranty period or 90 days from delivery to the customer, whichever is longer.

In order to receive the remedy set for above, you must contact during the warranty period and provide the model number, series number, proof of purchase, and date of purchase

## Appendix - Package list

| Item | Description             | Quantity | Remark |
|------|-------------------------|----------|--------|
| 1    | EV charger              | 1        |        |
| 2    | User Manual             | 1        |        |
| 3    | SD card                 | 1        |        |
| 4    | RFID Card               | 2        |        |
| 5    | Key of Cabinet          | 2        |        |
| 7    | 12/100" Expansion Screw | 4        |        |
| 8    | Sd Card reader          | 1        |        |

Address : Building 3, 3rd Floor, Granda Equipment Industrial Park, No. 33 Longtian Street, Pingshan District, Shenzhen City, Guangdong Province, China.

www.seconpower.com

Manufacturer: Shenzhen Secon Power Co., Ltd